

Lock Nut PLT Series

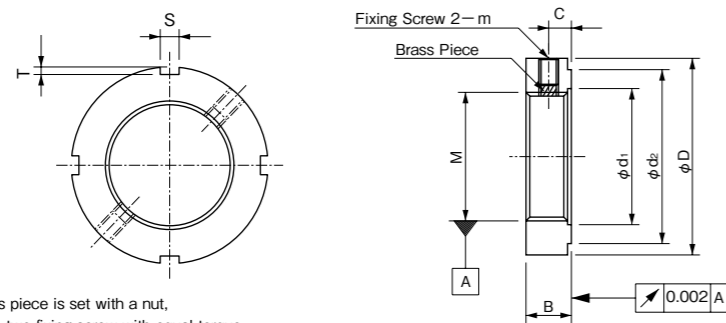

※ As a brass piece is set with a nut, tighten up two fixing screw with equal torque.

Lock Nut NLT Series

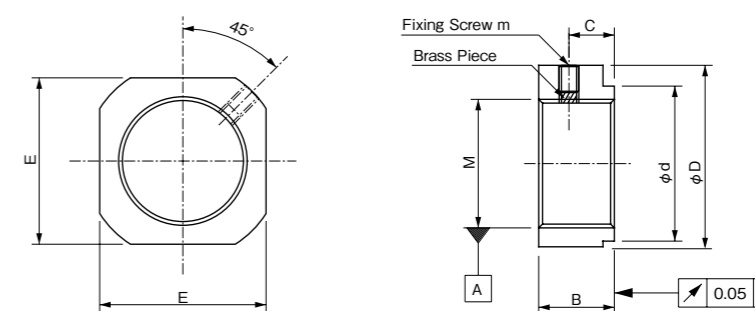

※ The fixing screw should be tightened up lightly after a brass piece is set in.

Unit : mm

Type	M	D	d ₁	d ₂	B	C	S	T	m
PLT-6	M 6×0.5	16	7	12	8	4	3	2	M4
PLT-8	M 8×0.75	16	9	11	8	4	3	2	M4
PLT-10	M10×0.75	18	11	13	8	4	3	2	M4
PLT-12	M12×1.0	22	13	18	8	4	3	2	M4
PLT-15	M15×1.0	25	16	21	8	4	3	2	M4
PLT-17	M17×1.0	28	18	23	10	5	4	2	M5
PLT-20	M20×1.0	32	21	27	10	5	4	2	M5
PLT-25	M25×1.5	38	26	33	12	6	5	2	M6
PLT-30	M30×1.5	45	31	40	12	6	5	2	M6
PLT-35	M35×1.5	52	36	47	12	6	5	2	M6

Unit : mm

Type	M	D	d	B	C	E	m
NLT-6	M6× 0.5	14	10	6	3.3	12	M3
NLT-8	M8× 0.75	16	11	6	3.3	13	M3
NLT-10	M10×0.75	20	16	7	4	17	M4
NLT-12	M12×1.0	22	18	7	4	19	M4
NLT-15	M15×1.0	25	20	10	6	21	M4
NLT-20	M20×1.0	35	26	13	6	30	M4