

Metric Coarse Screws

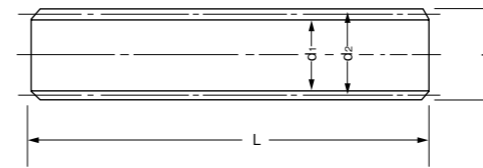
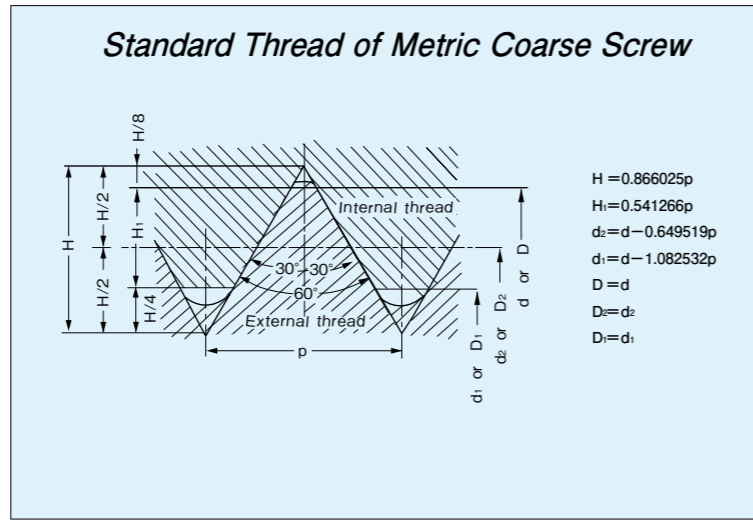
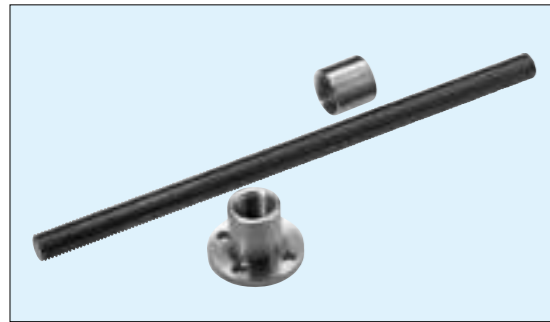

Chart of Metric Coarse Screw

Type	Length	Pitch	Outer Dia	Pitch Dia	Root Dia
	L	P	d	d ₂	d ₁
M 6	500	1	6.000	5.350	4.917
	1,000				
M 8	500	1.25	8.000	7.188	6.647
	1,000				
M10	500	1.5	10.000	9.026	8.376
	1,000				
M12	500	1.75	12.000	10.863	10.106
	1,000				
M16	500	2	16.000	14.701	13.835
	1,000				
M20	500	2.5	20.000	18.376	17.294
	1,000				
M24	500	3	24.000	22.051	20.752
	1,000				
M30	500	3.5	30.000	27.727	26.211
	1,000				
M36	500	4	36.000	33.402	31.670
	1,000				
	1,500				
	2,000				

Basic Dimensions of Metric Coarse Screw

Code			Pitch P	Thread Overlap H ₁	Internal thread		
(1)	(2)	(3)			D	D ₂	D ₁
					External thread		
					d	d ₂	d ₁
M5×0.8 M 6	M4.5		0.75	0.406	4.500	4.013	3.688
			0.8	0.433	5.000	4.480	4.134
			1	0.541	6.000	5.350	4.917
M 8	M 7 M 9		1	0.541	7.000	6.350	5.917
			1.25	0.677	8.000	7.188	6.647
M 10	M 11		1.25	0.677	9.000	8.188	7.647
			1.5	0.812	10.000	9.026	8.376
M 12			1.5	0.812	11.000	10.026	9.376
			1.75	0.947	12.000	10.863	10.106
M 16	M 14 M 18		2	1.083	14.000	12.701	11.835
			2	1.083	16.000	14.701	13.835
M 20			2.5	1.353	18.000	16.376	15.294
			2.5	1.353	20.000	18.376	17.294
M 24	M 22		2.5	1.353	22.000	20.376	19.294
			3	1.624	24.000	22.051	20.752
M 30	M 27 M 33		3	1.624	27.000	25.051	23.752
			3.5	1.894	30.000	27.727	26.211
M 36			3.5	1.894	33.000	30.727	29.211
			4	2.165	36.000	33.402	31.670
M 42	M 39		4	2.165	39.000	36.402	34.670
			4.5	2.436	42.000	39.077	37.129

Note: (1) Standard
(2) Substandard
(3) Notstandard

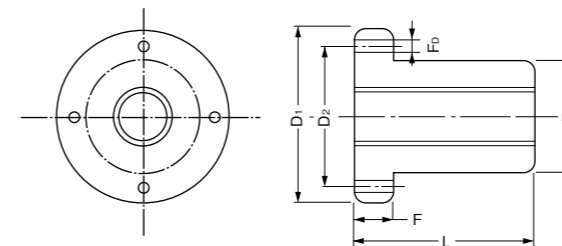

FNM Type Flange Nut

Type	Pitch P	Dimensions (mm)					
		D	L	F	D ₁	D ₂	F ₀
FNM 6	1	10	12	2	19	14	2.3
FNM 8	1.25	14	16	3	26	19	3.3
FNM10	1.5	14	16	3	26	19	3.3
FNM12	1.75	20	24	5	36	26	4.3
FNM16	2	20	24	5	36	26	4.3
FNM20	2.5	28	35	6	51	38	6.6
FNM24	3	28	35	6	51	38	6.6
FNM30	3.5	36	50	7	61	47	6.6
FNM36	4	44	56	8	76	58	9.0

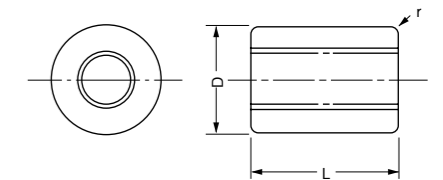

SNM Straight Nut

Type	Pitch P	Dimensions (mm)		
		D	L	r
SNM 6	1	10	10	1
SNM 8	1.25	14	14	1
SNM10	1.5	14	14	1
SNM12	1.75	20	20	1
SNM16	2	20	20	1
SNM20	2.5	28	26	1
SNM24	3	28	26	1
SNM30	3.5	36	40	1
SNM36	4	44	45	1.5

- Materials:
Screw...S45C
Nut...Up to M20 : BSBM
More than M24 : BC6 or equivalent
- Screw machined with precision thread rolling machine have maximum precision and minimum friction.
- Custom-made products and stainless steel products (SUS 304) are manufactured upon request.
- RoHS complied products are also available.