

TSK Miniature Guide LMBM-W Series (Wide Type)

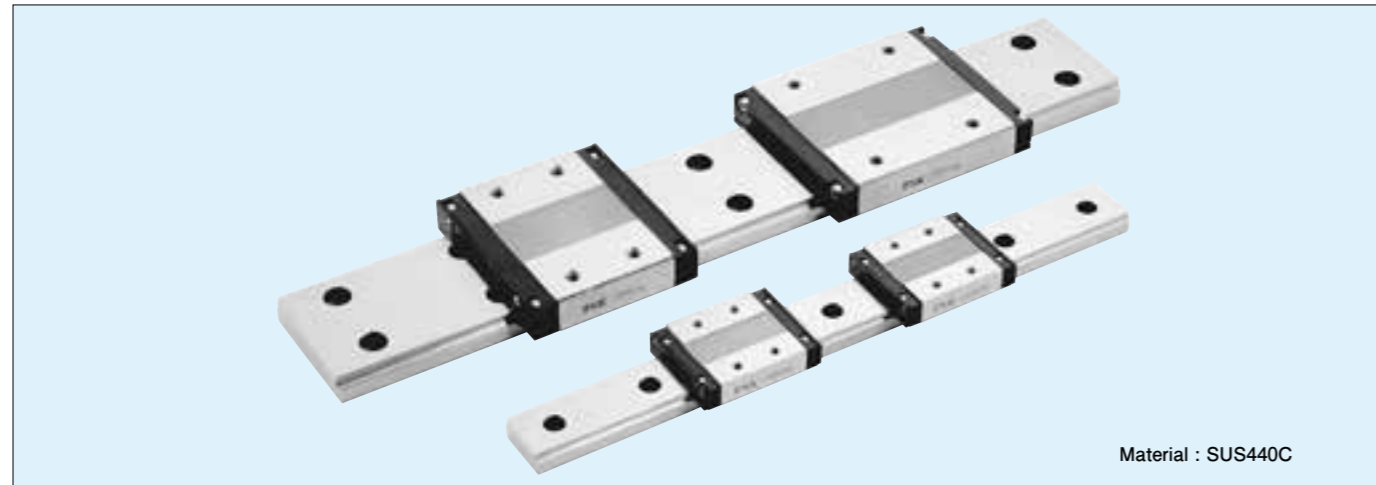

LMBM7W

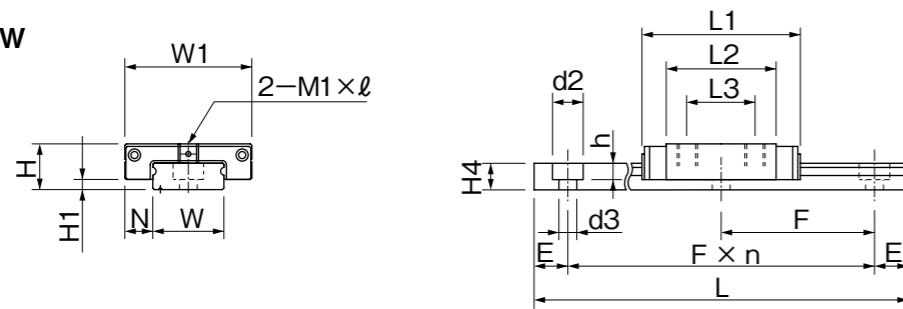

Model Number	Dimensions of Assembly			Slide Block Dimensions					
	H	H1	N	W1	W2	L1	L2	L3	M1 x l
LMBM 7W	9	2	5.5	25	-	31	21	12	M4 x 3.5
LMBM 7WS						39			
LMBM 7WL						41			
LMBM 7WLS						49			
LMBM 9WC	12	4.2	6	30	21	26.5	15.5	-	M2.6 x 3
LMBM 9WCS						34.5			
LMBM 9W						39			
LMBM 9WS						47			
LMBM 9WL						51			
LMBM 9WLS						59			
LMBM 12WC	14	4	8	40	28	30.5	16.5	-	M3 x 3.5
LMBM 12WCS						38.5			
LMBM 12W						44.5			
LMBM 12WS						52.5			
LMBM 12WL						59.5			
LMBM 12WLS						67.5			
LMBM 15WC	16	4	9	60	45	41.5	24.5	-	M4 x 4.5
LMBM 15WCS						51.5			
LMBM 15W						55.5			
LMBM 15WS						65.5			
LMBM 15WL						74.5			
LMBM 15WLS						84.5			

LMBM9W, 12W

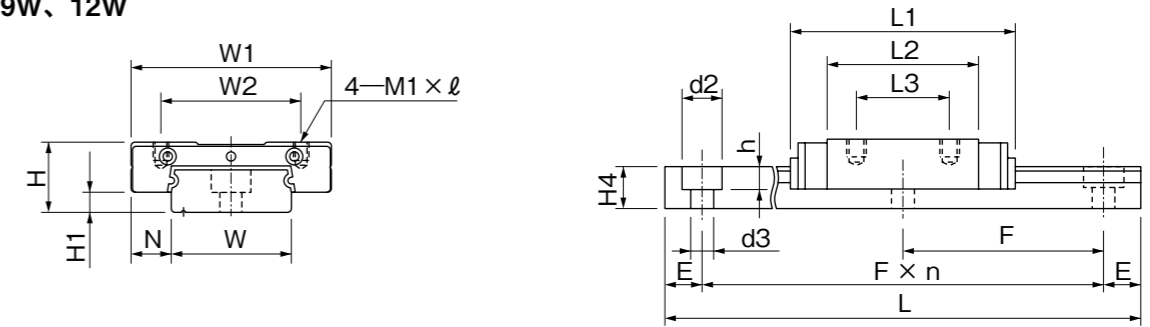

LMBM15W

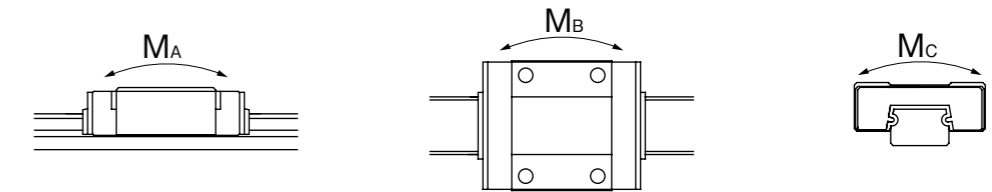
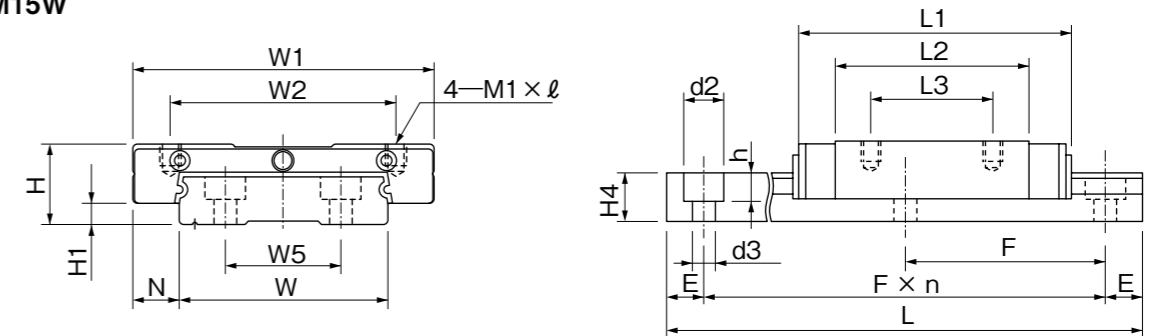

Rail Dimensions									Basic Load Rating [N]			Static Rated Moment [N · M]			Weight	
W	H4	W5	d2	d3	h	E	F	C	Co	MA	MB	MC	Block [kg]	Rail [kg/m]		
14	5.2	-	6	3.5	3.2	10	30	1360	2340	8.3	8.3	16.8	0.025	0.53		
								1740	3340	16.4	16.4	23.9	0.034			
18	7.5	-	6	3.5	4.5	10	30	1500	2120	5.8	5.8	19.4	0.024		0.99	
								2220	3710	16.5	16.5	34.0	0.039			
								2840	5290	32.6	32.6	48.5	0.053			
24	8.5	-	8	4.5	4.5	15	40	2350	3000	7.0	7.0	35.3	0.049	1.48		
								3620	5570	24.9	24.9	65.5	0.078			
								4720	8140	53.8	53.8	95.7	0.109			
													0.112			
42	9.5	23	8	4.5	4.5	15	40	4340	5530	24.0	24.0	114.0	0.117	2.84		
								6080	8980	50.9	50.9	185.0	0.166			
								7940	13130	110.2	110.1	270.5	0.233			

Code Name

