

TSK Miniature Guide LMBM Series

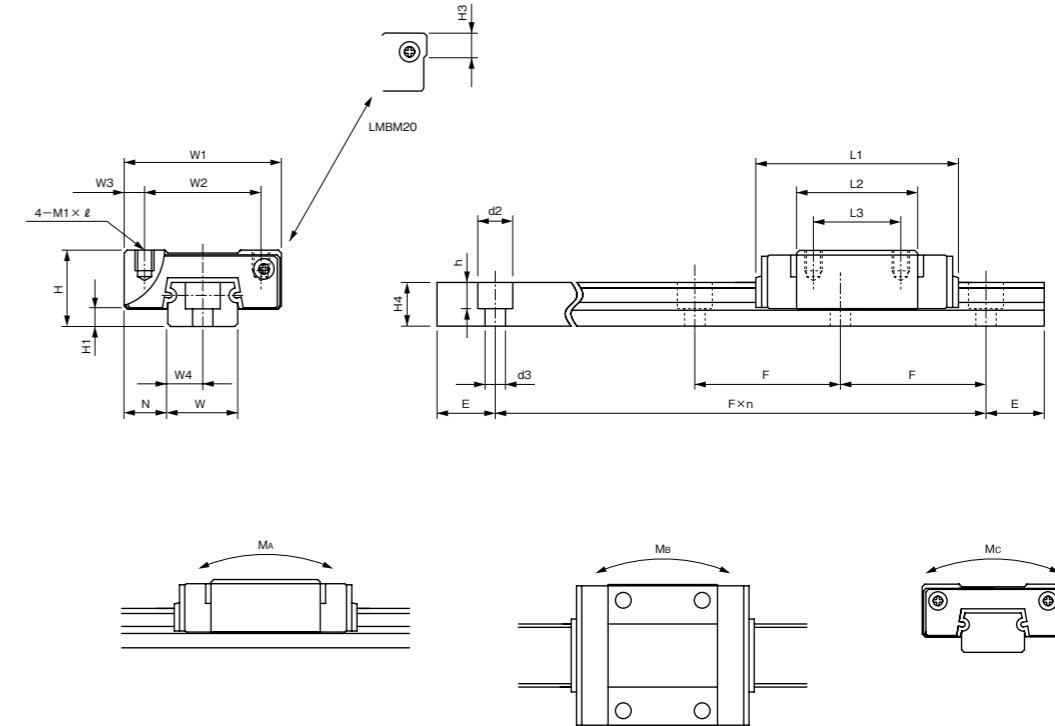

Model Number	Dimensions of Assembly						Slide Block Dimensions					M1 x l
	H	H1	N	W1	W2	W3	L1	L2	L3	H3		
LMBM 5	6	1.5	3.5	12	8	2	17	13	-	-	M2 x 1.5	
LMBM 5S							23					
LMBM 7C	8	1.5	5	17	12	2.5	19	9	-	-	M2 x 3	
LMBM 7CS							27					
LMBM 7							23.5	13.5	8			
LMBM 7S							31.5					
LMBM 7L							33	23	13			
LMBM 7LS							41					
LMBM 9C	10	2.2	5.5	20	15	2.5	21.5	10.5	-	-	M3 x 3	
LMBM 9CS							29.5					
LMBM 9							31	20	10			
LMBM 9S							39					
LMBM 9L							41	30	16			
LMBM 9LS							49					
LMBM 12C	13	3	7.5	27	20	3.5	25	10.8	-	-	M3 x 3.5	
LMBM 12CS							33					
LMBM 12							35	20.8	15			
LMBM 12S							43					
LMBM 12L							48	33.8	20			
LMBM 12LS							56					
LMBM 15C	16	4	8.5	32	25	3.5	32	14.7	-	-	M3 x 4	
LMBM 15CS							42					
LMBM 15							43	25.7	20			
LMBM 15S							53					
LMBM 15L							61	43.7	25			
LMBM 15LS							71					
LMBM 20C	25	7.5	13	46	38	4	38	16.5	-	6	M4 x 6	
LMBM 20CS							48					
LMBM 20							66.5	45	38			
LMBM 20S							76.5					
LMBM 20L							86.5	65	38			
LMBM 20LS							96.5					

Rail Dimensions								Basic Load Rating [N]		Static Rated Moment [N · M]			Weight	
W	W4	H4	d2	d3	h	E	F	C	Co	Ma	Mb	Mc	Block [kg]	Rail [kg/m]
5	2.5	4	3.5	2.4	1	5	15	430	770	1.3	1.3	2.1	0.005 0.005	0.14
7	3.5	4.7	4.2	2.4	2.3	5	15	750	1010	1.8	1.8	3.7	0.011 0.011	0.22
								1000	1510	3.0	3.0	5.6	0.013 0.014	
								1430	2510	8.3	8.3	9.2	0.019 0.020	
9	4.5	5.5	6	3.5	3.3	7.5	20	1220	1590	3.5	3.5	7.4	0.010 0.011	0.32
								1750	2650	8.8	8.8	12.4	0.018 0.019	
								2330	3970	16.5	16.5	18.5	0.027 0.028	
12	6	7.5	6	3.5	4.5	10	25	1730	2070	3.4	3.4	12.0	0.022 0.023	0.59
								2610	3720	11.3	11.3	21.4	0.037 0.038	
								3560	5790	32.2	32.2	33.3	0.056 0.058	
15	7.5	9.5	6	3.5	4.5	15	40	2880	3340	6.8	6.8	23.8	0.047 0.050	0.98
								4340	6000	23.2	23.2	42.6	0.070 0.074	
								5930	9340	65.8	65.8	66.4	0.109 0.112	
20	10	15	9.5	6	8.5	20	60	4610	5210	13.3	13.3	48.2	0.100 0.107	2.04
								8550	12500	96.0	96.0	115.7	0.238 0.244	
								10910	17710	165.7	165.7	163.9	0.334 0.340	

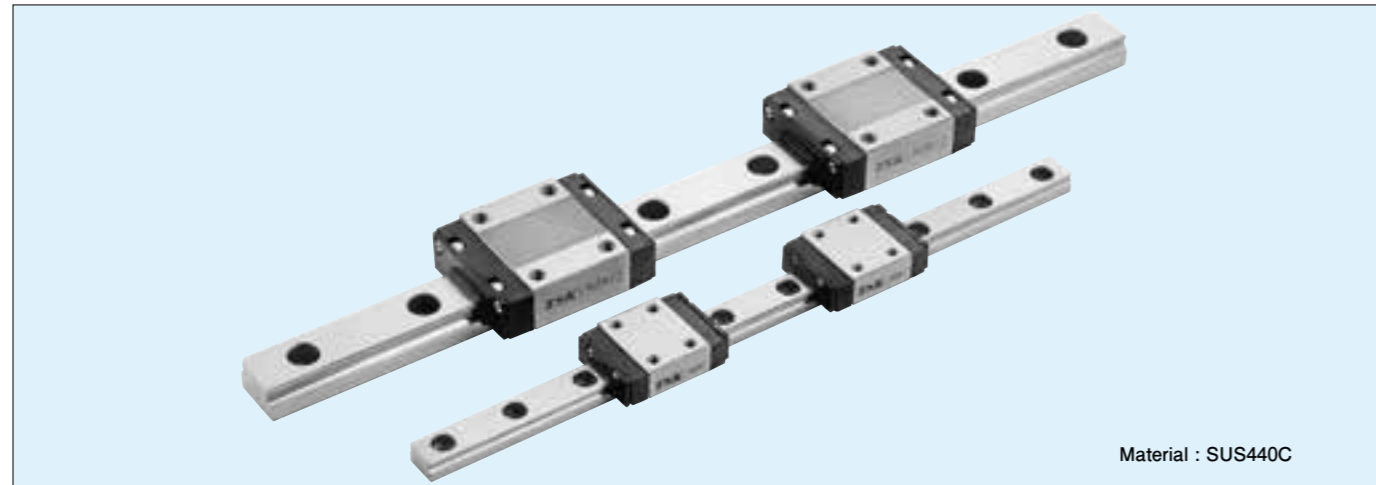